



Aerospace Industry
Engineered Access Solutions

Why Southco?

From cockpit to cabin, Southco offers a comprehensive product portfolio of latching, fastening and positioning technologies for a wide range of interior and exterior aircraft applications.

Our broad offering of engineered access solutions meets Aerospace industry requirements for strength, durability and compliance, enhances passenger comfort, and provides an extra layer of safety and security.



Total Program Management

Southco provides total program management, from initial design and prototyping to manufacturing and logistics:



Engineer-to-engineer connectivity



Industry standard products to meet global compliance specifications



Global supply and manufacturing presence with localized support



Off-the-shelf solutions suitable for high and low volume production



Innovative product design and development



Continuous improvement for defect-free manufacturing and on-time delivery



Aviation

Comfort, Functionality and Security

Southco products offer proven reliability and seamlessly integrate into Aerospace applications:

- Positioning Hinges and Display Mounting solutions improve the passenger experience
- Electronic Access Solutions increase cabin security and safety
- Push-to-Close Latches offer secure latching with visible and concealed mounting styles
- Multi-Point Latching Systems accommodate door misalignment and provide flexible actuation options, including remote actuation
- Draw and Compression Latches offer resilience and vibration resistance
- *DZUS*® Quick Access Fasteners enable easy maintenance and offer high cycle life
- *LOCKWELL*® Quick Release Pins offer dependable, fast removal for interior and exterior use



Positioning Technology Solutions

Southco's line of Positioning Hinges and Display Mounts ensure functionality and promote passenger comfort in cabin applications, enhancing ergonomics and usability.

- Integrated torque hinges allow the end user to easily adjust headrest wings, yet support full head weight
- Positioning hinges enable lightweight access panels to feel heavier and more substantial
- Display mounting options support inflight entertainment (IFE) systems, whether positioning a screen from the headrest or armrest

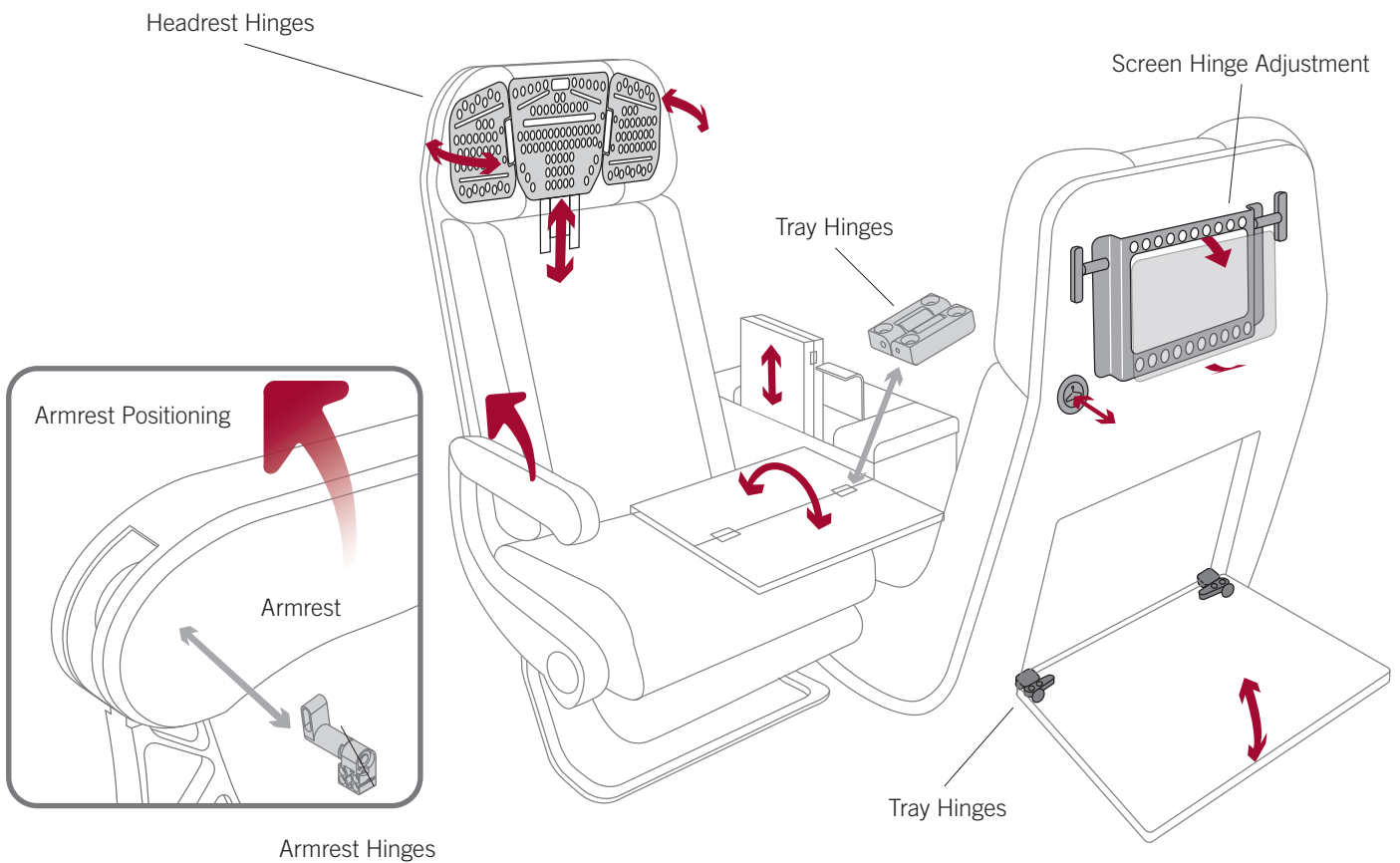
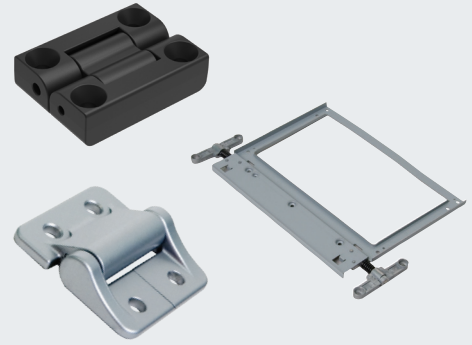

Electronic Access Solutions

Southco's Electronic Access Solutions (EAS) improve safety and security across the aircraft. Intelligent electronic locks provide reliable, secure latching, and remote access and control.

- Keep access points secure during take-off, taxi and landing, or turbulence
- Allow flight crew to remotely control passengers' access to overhead luggage bins, lavatories or food trays
- Secure and controlled access to crew-only areas, devices and storage boxes
- Compliance with RTCA DO-160 & DO-178B

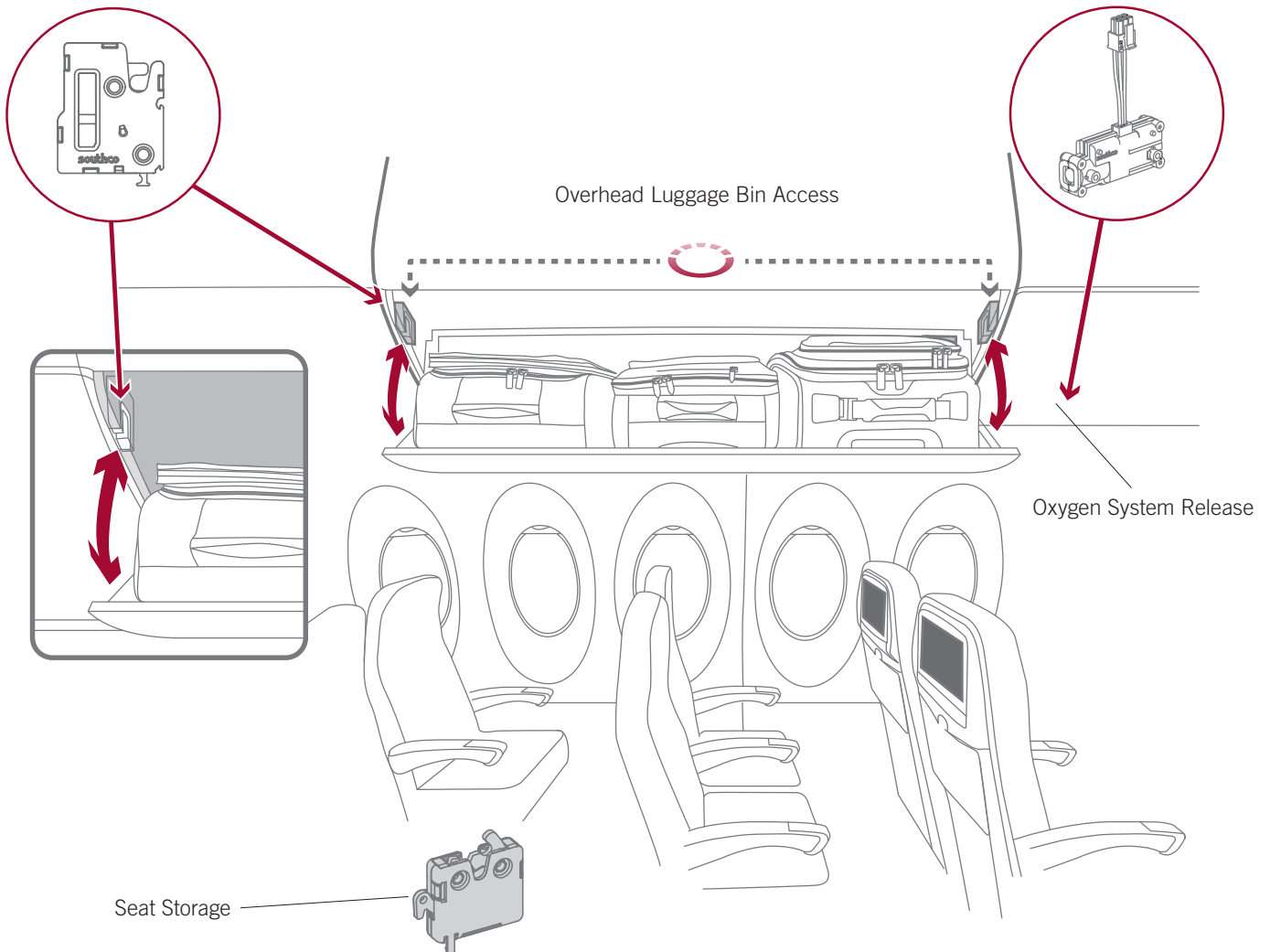
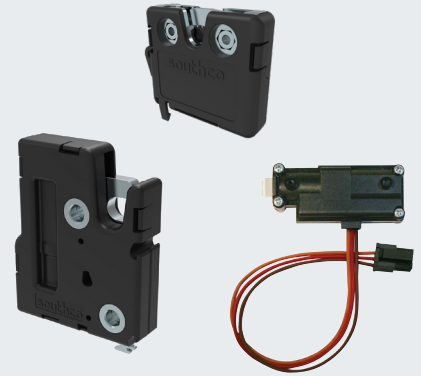

Wide Range of Applications

Maximizing the passenger flight experience and supporting the crew in performing tasks safely and securely are our key priorities.

SEATING



CABINS



OVERHEAD STORAGE



LAVATORY UNITS



GALLEYS



AVIONICS AND COCKPIT SYSTEMS

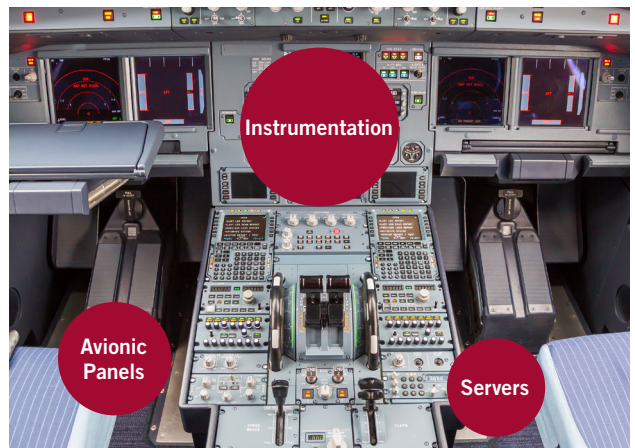

Wide Range of Products

Our products are engineered to improve passenger comfort, functional convenience and operational safety.

Positioning Technology & Hinges

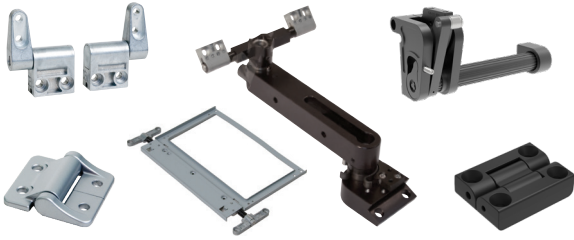

Electronic Access Solutions



Push-to-Close Latches



Compression Latches



Draw Latches



Multi-Point Latching Systems



Quick Access & Quarter-Turn Fasteners



Captive Screws & Inject / Eject Mechanisms



DZUS®

Lockwell®

southco®

About Southco

Southco, Inc. is the leading global designer and manufacturer of engineered access solutions. From quality and performance to aesthetics and ergonomics, we understand that first impressions are lasting impressions in product design. For over 70 years, Southco has helped the world's most recognized brands create value for their customers with innovative access solutions designed to enhance the touch points of their products in transportation and industrial applications, medical equipment, data centers and more.



**ELECTRONIC
ACCESS**



**DISPLAY
MOUNTS**



**COMPRESSION
LATCHES**



**CAM LATCHES,
LOCKS & SWING-
HANDLES**



**PUSH-TO-CLOSE
LATCHES**



**ROTARY
LATCHES**



**DRAW
LATCHES**



HINGES



**QUICK ACCESS
FASTENERS**



**CAPTIVE
SCREWS**



INJECT / EJECT



LIFT-A-SYST®

southco®

Americas Global Headquarters

Concordville, PA, USA
Tel: (1) 610 459 4000

Europe Headquarters

Worcester, UK
Tel: (44) (0) 1905 346722

Asia Pacific Headquarters

Hong Kong, China
Tel: (852) 3127 1503

WORLDWIDE MANUFACTURING AND STOCKING LOCATIONS

Concordville, Pennsylvania, USA · Honeoye Falls, New York, USA · Philadelphia, PA, USA · Chihuahua, Mexico · Tecate, Mexico · São Paulo, Brazil
Rzeszów, Poland · Farnham, UK · Worcester, UK · Hong Kong, China · Shenzhen, China · Shanghai, China · Seoul, Korea · Melbourne, Australia · Pune, India · Osaka, Japan